

# BHT FB 450° BECO PLUS

## Extreme Temperature Bearings



6000 SERIE

Designation	Bore (B)	Diam (D)	Width (W)	Speed, RPM	Static Load, kN at 450°C	Static Load, kN at 20°C
6000 BHT FB 450° BECO PLUS	10	26	8	90	1,22	1,96
6001 BHT FB 450° BECO PLUS	12	28	8	85	1,47	2,36
6002 BHT FB 450° BECO PLUS	15	32	9	80	1,78	2,85
6003 BHT FB 450° BECO PLUS	17	35	10	75	2,03	3,25
6004 BHT FB 450° BECO PLUS	20	42	12	70	3,12	5,00
6005 BHT FB 450° BECO PLUS	25	47	12	65	3,65	5,85
6006 BHT FB 450° BECO PLUS	30	55	13	60	5,00	8,00
6007 BHT FB 450° BECO PLUS	35	62	14	55	6,50	10,4
6008 BHT FB 450° BECO PLUS	40	68	15	50	7,37	11,8
6009 BHT FB 450° BECO PLUS	45	75	16	45	8,93	14,3
6010 BHT FB 450° BECO PLUS	50	80	16	40	9,75	15,6
6011 BHT FB 450° BECO PLUS	55	90	18	40	13,25	21,2
6012 BHT FB 450° BECO PLUS	60	95	18	40	14,50	23,2
6013 BHT FB 450° BECO PLUS	65	100	18	40	15,62	25,0
6014 BHT FB 450° BECO PLUS	70	110	20	40	19,69	31,5
6015 BHT FB 450° BECO PLUS	75	115	20	40	21,25	34,0

6200 SERIE

Designation	Bore (B)	Diam (D)	Width (W)	Speed, RPM	Static Load, kN at 450°C	Static Load, kN at 20°C
6200 BHT FB 450° BECO PLUS	10	30	9	90	1,62	2,60
6201 BHT FB 450° BECO PLUS	12	32	10	85	1,93	3,10
6202 BHT FB 450° BECO PLUS	15	35	11	80	2,34	3,75
6203 BHT FB 450° BECO PLUS	17	40	12	75	2,97	4,75
6204 BHT FB 450° BECO PLUS	20	47	14	70	4,09	6,55
6205 BHT FB 450° BECO PLUS	25	52	15	65	5,00	8,00
6206 BHT FB 450° BECO PLUS	30	62	16	60	7,00	11,2
6207 BHT FB 450° BECO PLUS	35	72	17	55	9,56	15,3
6208 BHT FB 450° BECO PLUS	40	80	18	50	11,2	18,0
6209 BHT FB 450° BECO PLUS	45	85	19	45	12,7	20,4
6210 BHT FB 450° BECO PLUS	50	90	20	40	15,0	24,0
6211 BHT FB 450° BECO PLUS	55	100	21	40	18,1	29,0
6212 BHT FB 450° BECO PLUS	60	110	22	40	22,5	36,0
6213 BHT FB 450° BECO PLUS	65	120	23	40	25,9	41,5
6214 BHT FB 450° BECO PLUS	70	125	24	40	27,5	44,0
6215 BHT FB 450° BECO PLUS	75	130	25	40	30,6	49,0

6300 SERIE

Designation	Bore (B)	Diam (D)	Width (W)	Speed, RPM	Static Load, kN at 450°C	Static Load, kN at 20°C
6300 BHT FB 450° BECO PLUS	10	35	11	90	2,15	3,45
6301 BHT FB 450° BECO PLUS	12	37	12	85	2,60	4,15
6302 BHT FB 450° BECO PLUS	15	42	13	80	3,38	5,40
6303 BHT FB 450° BECO PLUS	17	47	14	75	4,09	6,55
6304 BHT FB 450° BECO PLUS	20	52	15	70	5,30	8,50
6305 BHT FB 450° BECO PLUS	25	62	17	65	7,13	11,4
6306 BHT FB 450° BECO PLUS	30	72	19	60	10,1	16,3
6307 BHT FB 450° BECO PLUS	35	80	21	55	11,8	19,0
6308 BHT FB 450° BECO PLUS	40	90	23	50	15,6	25,0
6309 BHT FB 450° BECO PLUS	45	100	25	45	20,0	32,0
6310 BHT FB 450° BECO PLUS	50	110	27	40	23,7	38,0
6311 BHT FB 450° BECO PLUS	55	120	29	40	29,6	47,5
6312 BHT FB 450° BECO PLUS	60	130	31	40	32,5	52,0
6313 BHT FB 450° BECO PLUS	65	140	33	40	37,5	60,0
6314 BHT FB 450° BECO PLUS	70	150	35	40	42,5	68,0
6315 BHT FB 450° BECO PLUS	75	160	37	40	47,8	76,5

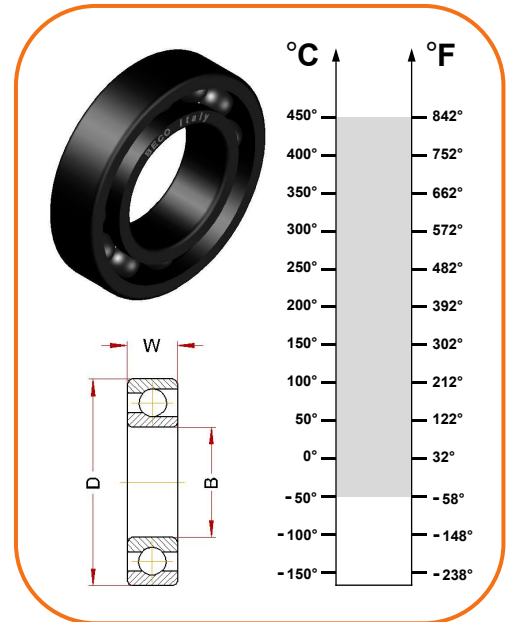

### Technical characteristics:

- Material steel AISI 52100 (Chrome) stabilized to the application
- Treatment of manganese phosphate coating on all steel parts + Treatment of ceramic coating
- Radial Clearance 4xC5
- Bearing running open

### Fields of application:

- Paint Ovens
- Steel industry
- Furnaces for Ceramic Industry
- Trolley Industry, Brick Kilns



12100 Cuneo - Italy  
Via Volta, 7  
phone: 0039 0171 66883  
fax: 0039 0171 648913

[www.becoitalia.it](http://www.becoitalia.it)